

# FREE VIBRATION ANALYSIS OF A COMPOSITE CYLINDER

L. BOUYAYA<sup>1</sup>, A. BELLAOUAR<sup>2</sup>

<sup>1,2</sup> University Frères Mentouri Constantine-1-, Department of Transport Engineering, Labo. LITE , ALGERIA

[bouyaya@yahoo.fr](mailto:bouyaya@yahoo.fr)

## Abstract:

Composite cylinders are high-strength containers made from a mixture of fiber glass or boron fibers and a plastic resin typically epoxy. A lamina is assumed to be homogeneous and the mechanical behavior is characterized by a set of equivalent or effective moduli and strength properties. In this paper, free vibration of composite cylindrical shells is studied by using Finite Element software ANSYS and analytical method. An eight noded isoparametric element is used for the discretisation of the proposed model.

The equations of motion are based on First-order Shear Deformation Theory (FSDT) of shell. The effects of transverse shear deformation and rotatory inertia are taken in to account. The governing equations are solved analytically using the Assumed-Modes Method. The effects of various parameters such as radius to side ratio, side to thickness ratio and different laminates on the free vibration responses are studied.

**Key words:** Composite cylinder, Free vibration, FEM, Fiber angle, Lamina.

## 1. Introduction

Cylindrical shells have been widely used for structural elements in various industries. Structural applications of multilayered composite cylindrical shells are on the increase due to their stiff, strong and lightweight materials.

The mechanical behaviors of laminated composite shells made of high-modulus and low-density materials are strongly dependent on the degree of orthotropy of individual layers, the low ratio of transverse shear modulus to the in-plane modulus and the stacking sequence of laminates. Free vibration has attracted the attention of many researchers up to the present are among the most important problem for laminated composite cylindrical shells even now.

In this regard many studies has been done in the past and the efforts being made to exploit the design strength of laminated structures through proper modelling and/or simulation.

From the above review it is evident that the free vibration behaviour of laminated composite cylindrical shells is currently an active area of research. It is also important to mention that now days the ANSYS is well

accepted modelling tool by different industries. However, ANSYS is capable to analyze the different linear and/or nonlinear responses of laminated structures with ease and the available literature related to ANSYS are limited in number. In the present study, the free vibration behaviour of laminated composite cylindrical panels has been investigated using ANSYS parametric design language (APDL) code developed in ANSYS.

## 2. Analytical Solution

Let us consider an orthotropic cylindrical shell formed from a number of layers. The co-ordinate system and loading condition are shown in Figure 1, where  $h$ ,  $R$ , and  $L$  denote wall thickness, mid-surface radius and cylinder length, respectively.

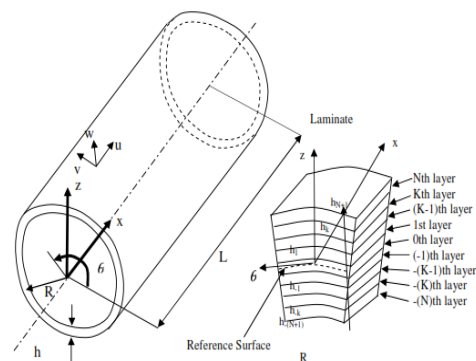

Fig.1. Material, element and structure co-ordinates of composite laminated cylindrical shell.

In First-order Shear Deformation Theory (FSDT), it is assumed that the transverse normal does not remain perpendicular to the mid surface after the deformation, Simplifying assumptions on displacement field that are used to derive the equilibrium equations are as follows:

- (1) The thickness of shell is small compared to the radius of shell ( $h/R \ll 1$ ).
- (2) The transverse normal stress is negligible.
- (3) Normals to the reference surface of the shell before deformation remain straight, but not necessarily normal, after deformation (a relaxed Kirchhoff-Love's hypothesis).

## 2.1 Displacement field

The Weierstrass theorem states that any function that is continuous in an interval may be approximated uniformly by polynomials in this interval. Thus, the displacement field in the shell can be represented by the following relationships:

$$\begin{aligned} U(x, \theta, z) &= u(x, \theta) + z\psi_x(x, \theta) + z^2\gamma_x(x, \theta) + \dots \\ V(x, \theta, z) &= v(x, \theta) + z\psi_\theta(x, \theta) + z^2\gamma_\theta(x, \theta) + \dots \\ W(x, \theta, z) &= w(x, \theta) + z\psi_z(x, \theta) + z^2\gamma_z(x, \theta) + \dots \end{aligned} \quad (1)$$

where U, V, and W are the displacement components in the directions of axes x,  $\theta$ , and z, respectively. The relaxed Kirchhoff-Love hypothesis stated in the third assumption results in the linearly distributed tangential displacements and a constant normal displacement through the thickness of the shell, and hence Eqs. (1) are simplified as follow:

$$\begin{aligned} U(x, \theta, z, t) &= u(x, \theta, t) + z\psi_x(x, \theta, t) \\ V(x, \theta, z, t) &= v(x, \theta, t) + z\psi_\theta(x, \theta, t) \\ W(x, \theta, z, t) &= w(x, \theta, t) + z\psi_z(x, \theta, t) \end{aligned} \quad (2)$$

where u, v, and w are the components of displacement at the middle surface in the x,  $\theta$ , and normal directions, respectively.  $\psi_x$  and  $\psi_\theta$  are the rotations of the normal to the middle surface during deformation about the x and  $\theta$  axes, respectively.

Based on (FSDT), the equilibrium equations for a cylindrical shell are as the following equations [11]:

$$\begin{aligned} \frac{\partial N_x}{\partial x} + \frac{1}{R} \frac{\partial N_{x\theta}}{\partial \theta} &= I_1 \frac{\partial^2 u}{\partial t^2} + I_2 \frac{\partial^2 \phi_x}{\partial t^2} \\ \frac{\partial N_{x\theta}}{\partial x} + \frac{1}{R} \frac{\partial N_\theta}{\partial \theta} &= I_1 \frac{\partial^2 v}{\partial t^2} + I_2 \frac{\partial^2 \phi_\theta}{\partial t^2} \\ \frac{\partial Q_x}{\partial x} + \frac{1}{R} \frac{\partial Q_\theta}{\partial \theta} - \frac{N_\theta}{R} &= I_1 \frac{\partial^2 w}{\partial t^2} \\ \frac{\partial M_x}{\partial x} + \frac{1}{R} \frac{\partial M_{x\theta}}{\partial \theta} - Q_x &= I_3 \frac{\partial^2 \phi_x}{\partial t^2} + I_2 \frac{\partial^2 u}{\partial t^2} \\ \frac{\partial M_{x\theta}}{\partial x} + \frac{1}{R} \frac{\partial M_\theta}{\partial \theta} - Q_\theta &= I_3 \frac{\partial^2 \phi_\theta}{\partial t^2} + I_2 \frac{\partial^2 v}{\partial t^2} \end{aligned} \quad (3)$$

In the above equation  $\phi_x$  and  $\phi_\theta$  are the slope in the plane of (x-z) and ( $\theta$ -z) respectively.

$I_1, I_2, I_3$  are defined by the following relation [11]:

$$(I_1, I_2, I_3) = \sum_{k=1}^N \int_{z_{k-1}}^{z_k} \rho_x(1, z, z^2) dz \quad (4)$$

where  $\rho_x$  is the density for each layer.

The boundary conditions for the cylindrical shell which are simply supported along its curved edges at  $x = 0$  and  $x = L$  are considered as what follows [10]:

$$\begin{aligned} N_x(0, \theta, t) &= N_x(L, \theta, t) = 0 \\ M_x(0, \theta, t) &= M_x(L, \theta, t) = 0 \\ W(0, \theta, t) &= W(L, \theta, t) = 0 \\ V(0, \theta, t) &= V(L, \theta, t) = 0 \\ \phi_\theta(0, \theta, t) &= \phi_\theta(L, \theta, t) = 0 \end{aligned} \quad (5)$$

## 2.4 Solution

The governing equations above are solved analytically by using Assumed-Modes method. For the simply supported boundary conditions, the displacement and curvature change function are taken to be.

The following functions are assumed to satisfy the simply-supported boundary conditions and the equations of motion:

$$\begin{aligned} u(x, \theta, t) &= \sum_{m=1}^{\infty} \sum_{n=1}^{\infty} U_{mn} \cos(\alpha x) \sin(n\theta) \sin(\omega t) \\ v(x, \theta, t) &= \sum_{m=1}^{\infty} \sum_{n=1}^{\infty} V_{mn} \sin(\alpha x) \cos(n\theta) \sin(\omega t) \\ w(x, \theta, t) &= \sum_{m=1}^{\infty} \sum_{n=1}^{\infty} W_{mn} \sin(\alpha x) \sin(n\theta) \sin(\omega t) \\ \phi_x(x, \theta, t) &= \sum_{m=1}^{\infty} \sum_{n=1}^{\infty} X_{mn} \cos(\alpha x) \sin(n\theta) \sin(\omega t) \\ \phi_\theta(x, \theta, t) &= \sum_{m=1}^{\infty} \sum_{n=1}^{\infty} Y_{mn} \sin(\alpha x) \cos(n\theta) \sin(\omega t) \end{aligned} \quad (6)$$

where  $\alpha_m = \frac{m\pi}{L}$  and  $\omega$  is the natural frequency of the system

Now, substituting Eq. (6) in to Eq. (3) and then enforcing the result into Eq. (9), the free vibration Eigen-equations yield to what follows:

$$\begin{aligned} ([C] - \omega^2 [M])U &= 0 \\ U &= (U_{mn}, V_{mn}, W_{mn}, X_{mn}, Y_{mn})^T \end{aligned} \quad (7)$$

Where [C] and [M] are stiffness and mass matrices respectively and.

## 3. Problem modeling

As the first step, the geometry of the cylindrical panel with the desired material properties is created in the ANSYS 11 environment using APDL code. The model is then discretized into the required mesh configuration using the eight noded isoparametric Serendipity element (SHELL99) from the ANSYS element library. Further, the model is subjected to desired boundary conditions in order to constrain its degrees of freedom at all the nodal position of the edges. Finally, free vibration analysis of the present model is carried out by Block Lanczos

method in ANSYS 11 environment based on inbuilt FSĐT.

Boron/Epoxy are as follows:  $E_1=224$  GPa,  $E_2=12.7$  GPa,  $G_{12}=G_{13}=4.42$  GPa,  $\nu_{12}=0.256$ ,  $\rho=2527$  kg/m<sup>3</sup>.

#### 4. Analysis and discussion of results

The results of free vibration of laminated cylindrical shells are presented. The examples geometry, material and support conditions are taken same as the references. The same geometric parameters are obtained at the mid-length of the shell Material properties in a single layer of

The effect R/h and L/R ratios on nondimensional fundamental natural frequency ( $\bar{\omega}$ ) of three different cross-ply laminate ( $[0^0/90^0]$ ,  $[0^0/90^0/0^0]$ ,  $[0^0/90^0/90^0/0^0]$ ) of a simply supported cylindrical shell is shown in Table 1, 2 and 3, respectively. The results can be seen that as the h/R ratio increases the frequency value decreases and which is expected for any structural case.

Table 1: Non-dimensional fundamental frequencies ( $\bar{\omega}$ ) =  $\omega R / \sqrt{\frac{\rho}{E_2 k}}$  of  $[0^0/90^0]$  simply supported cylindrical shells for different values of R/h and L/R ratios.

[0 <sup>0</sup> /90 <sup>0</sup> ]	Analytical			Ansys		
	L/R=1	L/R=5	L/R=10	L/R=1	L/R=5	L/R=10
0.001	0.5867	0.2328	0.1341	0.6007	0.2228	0.1021
0.002	0.8378	0.2630	0.1745	0.9008	0.2740	0.1785
0.003	1.1229	0.2951	0.1810	1.1059	0.2992	0.2510

Table 2: Non-dimensional fundamental frequencies ( $\bar{\omega}$ ) =  $\omega R / \sqrt{\frac{\rho}{E_2 k}}$  of  $[0^0/90^0/90^0/0^0]$  simply supported cylindrical shells for different values of R/h and L/R ratios.

[0 <sup>0</sup> /90 <sup>0</sup> /90 <sup>0</sup> /0 <sup>0</sup> ]	Analytical			Ansys		
	L/R=1	L/R=5	L/R=10	L/R=1	L/R=5	L/R=10
0.001	1.1217	0.4314	0.2441	0.9007	0.3478	0.2827
0.002	1.7178	1.6131	1.2045	1.3768	1.3015	0.2785
0.003	1.8214	1.5052	1.3810	1.3756	1.6251	1.2010

#### 5. Conclusion

The model is developed using six degrees of freedom, eight noded linear layered structural shell element (shell 99) in APDL environment of commercially available software ANSYS 11. The computer code has been developed for free nondimensional natural frequency characteristic of cross-ply cylindrical panels. It can be concluded that the present results are converging well with very small difference in comparison to the FE method. Nondimensional fundamental natural frequency ( $\bar{\omega}$ ) of simply supported cross-ply cylindrical shells are decreasing with an increase in curvature ratio (L/R) increases with increase in thickness ratio (h/R). It can also be seen that the frequency value increases with increase in the number of layers.

#### 6. References

- [1] N. Reddy, C. F. Liu, , *A Higher-order shear deformation theory of Laminated Elastic Shells*, Int J of Engg Sci, vol .23, pp. 319330, 1985.
- [2] M. Ganapathi, M. Haboussi, *Free vibrations of thick laminated anisotropic non-circular cylindrical shells*, Composite Structures, vol. 60, pp. 125-133, 2003.
- [3] N.V.S. Naidu, P.K. Sinha, *Nonlinear finite element analysis of laminated composite shells in hygrothermal environments*, Compos Struct, vol. 69, pp. 387–395, 2005.
- [4] S. Pradyumna, J.N., *Free vibration analysis of functionally graded curved panels using a*

*higher-order finite element formulation*, Journal of Sound and Vibration, vol.318, pp.176–192, 2008.

- [5] Namita Nanda, J. N., *Nonlinear Free Vibration Analysis of Laminated Composite Cylindrical Shells with Cutouts*, DOI:10.1177/0731684407079776.
- [6] D. Chakravorty, J.N., Sinha, *finite element free vibration analysis of point supported laminated composite cylindrical shells*, Journal of Sound and Vibration, vol. 181(1), pp. 43-52, 1995.
- [7] K.Y. Lam, Wu Qian, *Free vibration of symmetric angle-ply thick laminated composite cylindrical shells*, Composites, vol. 31, pp. 345–354, 2000.
- [8] X.M. Zhang, *Vibration analysis of cross-ply laminated composite cylindrical shells using the wave propagation approach*, Applied Acoustics, vol. 62, pp.1221–1228, 2001.